

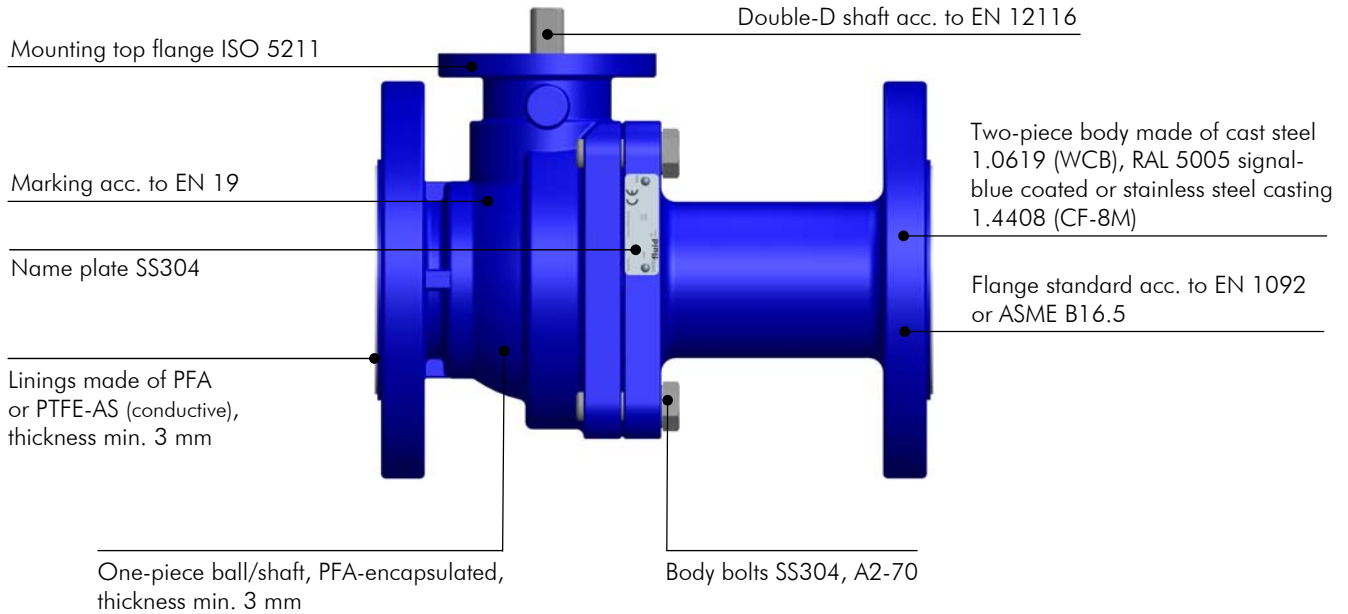

**Construction of Valve**



**Mounting Options**

