

1/2" – 6"

SST Sight Glasses are ideally suited as reliable flow indicators for virtually all existing process media in either liquid or even gaseous state.

Modular Design

The Sight Glasses are available with glass window plates made of Borosilicate acc. to DIN 7080 as per standard.

The sturdy design bodies are made of stainless steel casting 1.4408 (CF-8M) or welded constructions made of 1.4404 (CF-3M).



SST-FD (flanged)
Body/cover CF-8M



SST-BW (butt welding ends)
Body CF-3M/cover CF-8M

Main Features

- Heavy-duty, proven construction - maintenance-free
- Horizontal or vertical installation, flange connections acc. to ANSI 150lbs (DIN PN16/40 optional)
- Standard drip ledge indicating even minute flows
- Large observation opening

 **Conformity according to European Pressure Equipment Directive 2014/68/EU (PED)**

Options

- Metal reinforced glass plates
- Quartz glasses
- FEP glass protection sheet
- Visual flow indicator for gases (PTFE ribbon)

Operating Conditions

- Temperature range from -40°F up to +450°F
- Pressure range from 0.01 psia up to 232 psi

Testing / Marking

- Pressure- and tightness testing acc. to EN 12266-1, leakage rate A, resp. API 598.
- Marking of valves on body and name plate acc. to EN 19.
- Material- resp. test certificates acc. to EN 10204-3.1/2.2/2.1

Technical Data

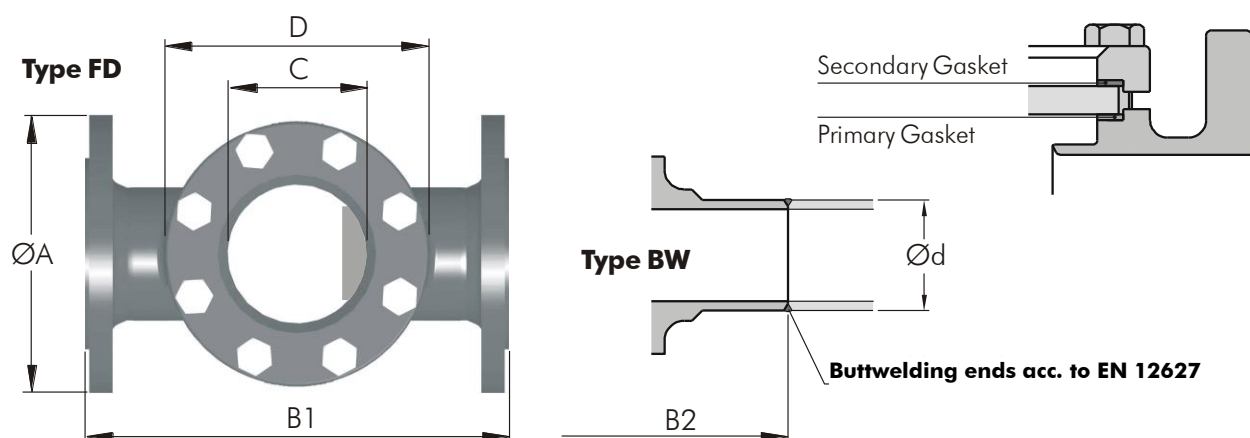

Standard Materials of Components

Body	Stainl. steel casting 1.4408 (CF-8M) for type FD, 1.4404 (CF-3MN) for type BW
Flange	Stainl. steel casting 1.4408 (CF-8M)
Glass Plate	Borosilicate 8488 acc. to DIN 7080
Gasket (primary)	PTFE-T (modified)
Gasket (second.)	C-4400 asbestos-free
Bolts	SS304

Dimensions inch / Weights lbs

DN	1/2"	3/4"	1"	1 1/4"	1 1/2"	2"	2 1/2"	3"	4"	6"
ØA	3.74	4.13	4.25	4.61	5.00	6.00	7.00	7.50	9.00	11.00
B1 FD	5.12	5.91	6.30	7.09	7.87	9.06	11.42	12.20	13.78	18.90
B2 BW	5.12	5.91	6.30	7.09	7.87	9.06	11.42	12.20	13.78	18.90
ØC	1.30	1.30	1.89	1.89	2.56	3.15	3.15	3.94	4.92	7.87
D	□2.76	□2.76	□3.35	□3.35	□4.33	□4.72	Ø6.89	Ø7.48	Ø8.27	Ø11.42
Ød	0.84x0.08	1.06x0.09	1.33x0.10	1.67x0.10	1.90x0.10	2.37x0.11	3.00x0.11	3.5x0.13	4.5x0.14	6.63x0.18
ØGlass	1.77x0.39	1.77x0.39	2.48x0.39	2.48x0.39	3.15x0.47	3.94x0.59	3.94x0.47	4.92x0.79	5.90x0.98	8.86x1.18
lbs appr. FD	5.72	7.48	10.34	15.18	16.28	21.34	38.50	55.00	83.60	121.00
lbs appr. BW	3.30	3.96	5.72	6.82	8.58	11.22	22.00	34.10	55.00	86.90

B1 acc. to DIN EN 558-1 Range 1 **B2** acc. to DIN EN 12982
 other materials or dimensions (e.g. ANSI lengths) upon request

Options

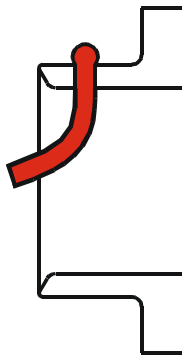

**Visual
Flow Indicator**

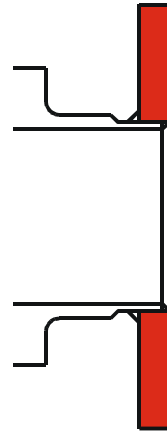

**Flanges acc. to
ANSI 150lbs**

**PN40 (300lbs)
Special Glass**

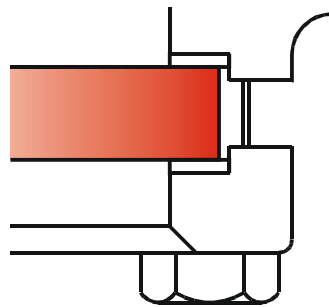

**Flanges with
Groove Form N
acc. to DIN 2512**

**Metal-reinforced
Glasses**

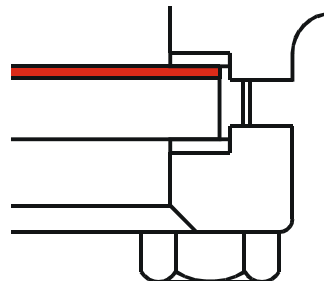
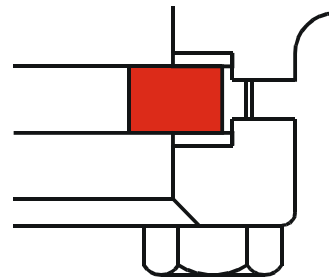

**FEP Glass
Protection Sheet**

SST Sight Glasses Stainless Steel

Parts List

Sight Glass compl.

Standard Version (Picture showing DN 80 PN16, body FD flanged version)

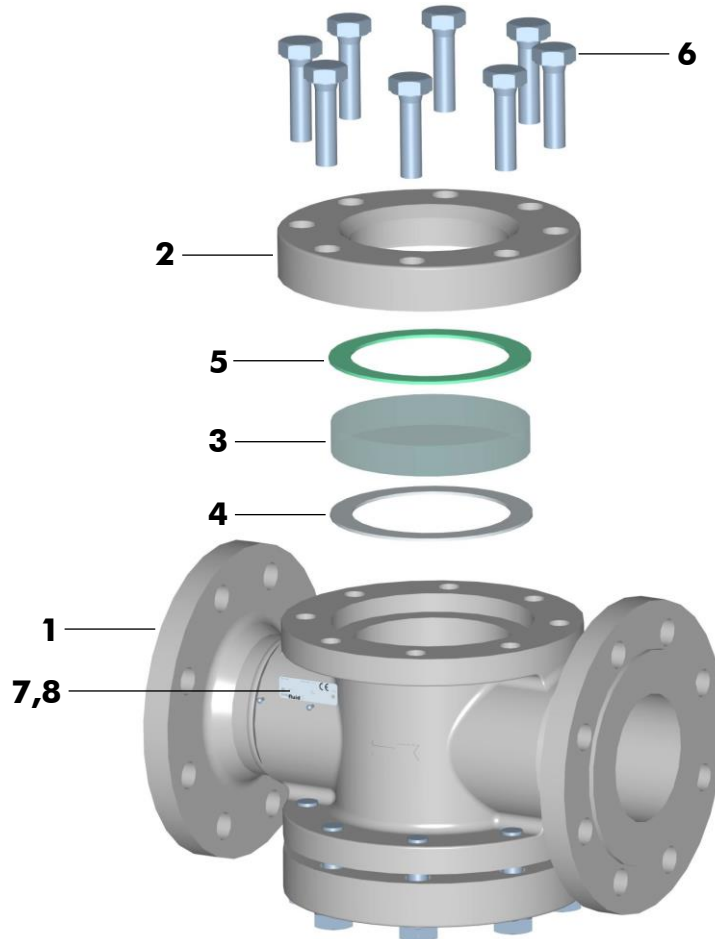

Item	Qty.	Description	Material	No.
1	1	Body *	CF-3M/SS316L	1.4404/1.4404
2	2	Flange	CF-8M	1.4408
3	2	Glass Plate DIN 7080	Borosilicate	8488
4	2	Gasket primary	PTFE-T	
5	2	Gasket secondary	C-4400	
6	16	Hex. Head Screw	A2-70	1.4310
7	1	Name Plate 42 x 14 CE	A2	1.4301
8	2	Hammer Screw 2.49 x 4.76	A2	1.4310

* Body welded, cons. of middle part CF-3M and flanges SS316L (1.4404 or 1.4435)
 1/2" - 2": flanged body one-piece, casting CF-8M (1.4408), buttweld CF-3M (1.4404)

Specification

Project-/Customer Data		Inquiry/Date: _____		Ref. SF _____	
Company:		Contact Person:		Phone:	
Address:		Function:		Fax:	
ZIP/Place:		Department:		E-mail:	
Project:		Phone direct:		Mobile:	

Operating Conditions

Media / Chemical Composition:

<input type="checkbox"/> liquid	<input type="checkbox"/> powdery	<input type="checkbox"/> crystallizing	<input type="checkbox"/> sticky	<input type="checkbox"/> Spec. Grav. ____
<input type="checkbox"/> gaseous	<input type="checkbox"/> Solids ____ %	<input type="checkbox"/> viscous	<input type="checkbox"/> Flow Velocity ____ ft/sec	
<input type="checkbox"/> abrasive	<input type="checkbox"/> Particle ____ mm	<input type="checkbox"/> Visc. ____ cp	<input type="checkbox"/> Flow Rate ____ usg/min	

Pressure	Temperature	Mode	Installation / Environment	
max. ____ bar	max. ____ °C	<input type="checkbox"/> On/Off	<input type="checkbox"/> horizontal	<input type="checkbox"/> Room dry
min. ____ bar	min. ____ °C	<input type="checkbox"/> Flow Control	<input type="checkbox"/> vertical	<input type="checkbox"/> Room humid
		____ cycles/ ____	<input type="checkbox"/> _____	<input type="checkbox"/> outdoor

Remarks:

SST Product Code

Specification of a complete Sight Glass SST Series

Product code	Nom. size	Flange conn.	Type	Body	Glass plate	Options
SST	2"	150lbs	FD	G15	Gb	
	<input type="checkbox"/> 1/2" - 6" <input type="checkbox"/> DN15 - 150	<input type="checkbox"/> ANSI150# <input type="checkbox"/> ANSI300# <input type="checkbox"/> PN16 <input type="checkbox"/> PN40 <input type="checkbox"/> JIS 10K	<input type="checkbox"/> FD Flanged <input type="checkbox"/> BW Buttweld	<input type="checkbox"/> G15 CF-8M <input type="checkbox"/> G14 CF-3M	<input type="checkbox"/> Gb Glass plate PN16 <input type="checkbox"/> Gb40 Glass plate PN40 <input type="checkbox"/> Gr reinforced glass <input type="checkbox"/> Gq Quartz glass	<input type="checkbox"/> Gf FEP prot. sheet <input type="checkbox"/> Op visual flow ind.